

AXIAL FLOW FANS DIMENSIONS

AP & APS SERIES

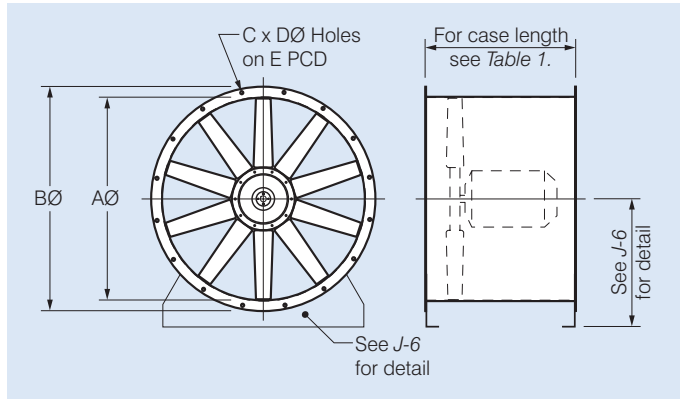

Model Number	Dimensions, mm				
AP./APS./APB./APEC./APPM.	AØ	BØ	C	DØ	E
031	315	380	8	10	355
040	400	485	8	12	450
050	500	585	12	12	560
056	560	645	12	12	620
063	630	715	12	12	690
071	710	795	16	12	770
080	800	885	16	12	860
100	1000	1106	16	15	1070
125	1250	1356	20	15	1320
140	1400	1526	20	15	1470
160	1600	1730	24	19	1680
180	1800	1960	24	19	1880
200	2000	2160	24	19	2080

APH SERIES

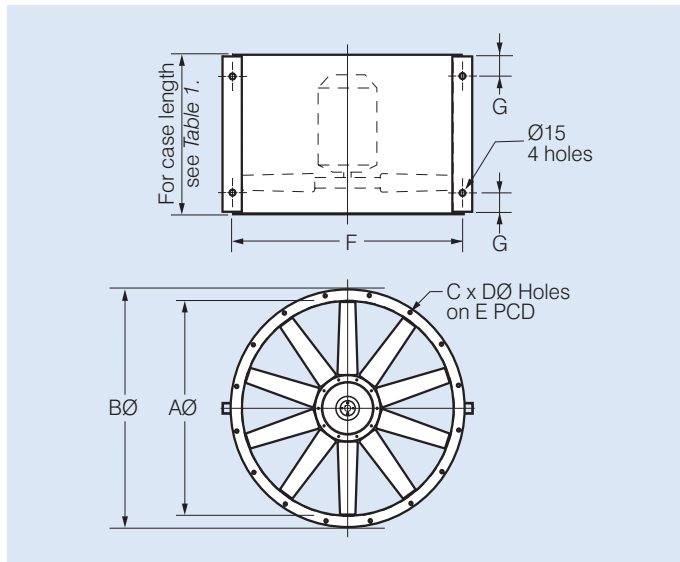

Model Number	Dimensions, mm						
APH.	AØ	BØ	C	DØ	E	F	G*
31	315	380	8	10	355	370	
40	400	485	8	12	450	455	
50	500	585	12	12	560	555	
56	560	645	12	12	620	615	50
63	630	715	12	12	690	685	
71	710	795	16	12	770	765	
80	800	885	16	15	860	855	
100	1000	1106	16	15	1070	1096	
125	1250	1356	20	15	1320	1346	95
140	1400	1526	20	15	1470	1496	
160	1600	1730	24	19	1680	1696	

* Dimension G is from inside of flange to hole centre

APB SERIES

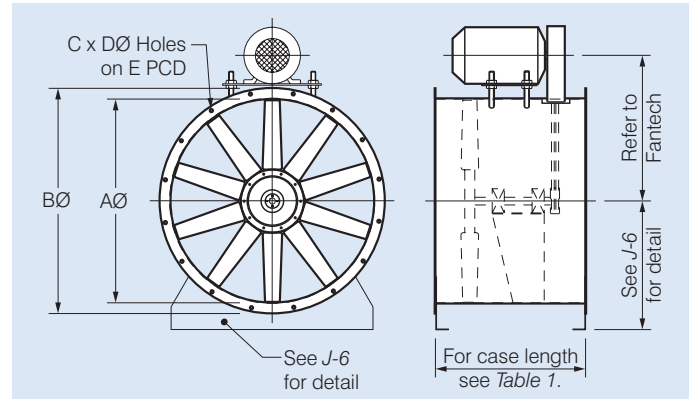

Table 1. Motor frame size	Casing length, mm			
	AP./APS./APH./APEC./APPM.	APV	APB	BFA
D71	300	400	400	600
D80	400	400	400	600
D90	400	400	400	800
D100	450	600	600	800
D112	450	600	600	800
D132	600	600	600	800
D160	800	800	800	1000
D180	800	800	800	1000
D200	1000	1000	1000	1000
D225	1000	1000	1000	1000
D250	1000	1000	1000	-
D280	1200	1200	1200	-
D315	1500	1500	1300	-

NOTE: To determine the weight of any selection refer to pages C-28/29 where detailed casing, impeller and motor weights are listed. The total weight is the sum of all three components.

Ancillary equipment is detailed in pages H-1, J-1 & L-1. Motor ratings and speeds, other than those shown, can be provided. Two-speed motors are also available.

Table 2. Table of kW ratings

Frame Size	Number of Poles			
	2 48 rev/sec	4 24 rev/sec	6 16 rev/sec	8 12 rev/sec
D71	0.37/0.55	0.37	-	-
D80A	0.75	0.55	0.37	-
D80A	1.1	0.75	0.55	-
D90S	1.5	1.1	0.75	-
D90L	2.2	1.5	1.1	0.55
D100L	3.0	2.2	1.5	0.75
D100L	-	3.0	-	1.1
D112M	4.0/5.5	4.0	2.2	1.5
D132S	5.5/7.5	5.5	3.0	2.2
D132M	-	7.5/10.0	4.0/5.5	3.0
D160M	11.0/15.0	11.0	7.5	4.0/5.5
D160L	18.5	15.0	11.0	7.5
D180M	22.0	18.5	-	-
D180L	-	22.0	15.0	11.0
D200L	30.0/37.0	30.0	18.5/22.0	15.0
D225S	-	37.0	-	18.5
D225M	45.0	45.0	30.0	22.0
D250S	-	-	37.0	30.0
D250M	55.0	55.0	45.0	37.0
D280S	75.0	75.0	55.0	45.0
D280M	90.0	90.0	75.0	55.0

The above table should be used as a guide only as kW ratings/frame size can vary from one manufacturer to another.

AXIAL FLOW FANS DIMENSIONS

APV SERIES

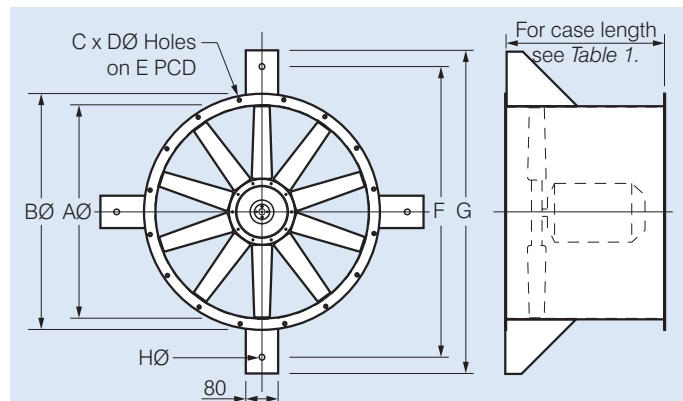

Model Number	Dimensions, mm							
	AØ	BØ	C	DØ	E	F	G	HØ
APV..								
0312								
0314	315	380	8	10	355	531	611	14
0316								
0402								
0404	400	485	8	12	450	618	698	14
0406								
0502								
0504	500	585	12	12	560	720	800	14
0506								
0562								
0564	560	645	12	12	620	780	860	14
0566								
0632								
0634	630	715	12	12	690	851	931	14
0636								
0638								
0712								
0714	710	795	16	12	770	931	1011	14
0716								
0718								
0804								
0806	800	885	16	12	860	1022	1102	14
0808								
1004								
1006	1000	1106	16	15	1070	1296	1396	14
1008								
1254								
1256	1250	1356	20	15	1320	1548	1648	14
1258								
1404								
1406	1400	1526	20	15	1470	1703	1803	14
1408								
1606								
1608	1600	1730	24	19	1680	1904	2004	14
1601								
1806								
1808	1800	1960	24	19	1880	2105	2205	14
1801								
2006								
2008	2000	2160	24	19	2080	2305	2405	14
2001								

BFA SERIES

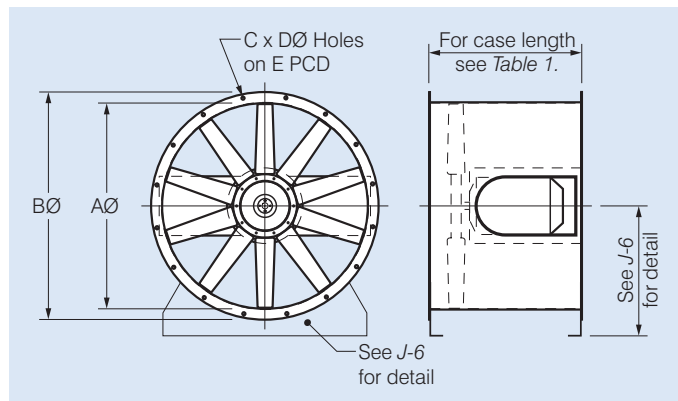

NOTE: When the fan is mounted horizontally, the cooling tunnel should be in the vertical plane when installed. Refer to page C-7 for special notes that affect selection.

Model Number	Dimensions, mm				
	AØ	BØ	C	DØ	EØ
BFA..					
0402					
0404	400	463	8	12	438
0502					
0504	503	567	8	12	541
0562					
0564	560	644	16	12	605
0634					
0636	635	721	16	12	674
0714					
0716	716	802	16	12	765
0804					
0806	807	893	16	12	865
1004					
1006	1004	1114	16	12	1070
1008					
1254					
1256	1256	1366	16	14	1320
1258					

Unit weights can be determined from pages C-28/29.